

# AS/NZS 3500 LEGAL REQUIREMENTS

## 3.16 RE-USE OF EXISTING SANITARY DRAINS

### 3.16.1 Re-use where buildings are demolished or removed

When a building containing sanitary plumbing and drainage is demolished or removed from site and a new building constructed, the following requirements shall apply to the use of existing sanitary drains up to the point of connection:

(a) Mortar-jointed vitrified clay, mortar-jointed concrete, asbestos cement and fiber-reinforced cement pipes shall not be re-used unless they have been renovated using a structural plastics liner in accordance with Clause 3.16.3.

AS/NZS 3500.2:2018 34

(b) Drains constructed of other materials shall not be re-used unless they have been verified for conformance in accordance with the relevant clauses of this Standard and tested in accordance with Section 15 and found to be satisfactory.

Drains that do not conform with requirements listed above shall be replaced or repaired and retested.

### 3.16.2 Re-use in existing buildings

For an existing building, including alterations or additions that will involve additional fixtures being connected to the existing drain, if that section of the existing drain is found to be defective it shall be renovated in accordance with Clause 3.16.3 or a new section of drain installed.

### 3.16.3 Renovation techniques

#### 3.16.3.1 Cured in place pipe (CIPP)

The renovation of a drain by the CIPP technique shall be in accordance with Appendix F with the exception of Clause F3(g) which does not apply.

NOTE: CIPP renovation is the lining of a drain with a flexible tube impregnated with a thermosetting resin. This produces a rigid pipe after the resin has cured.

# Appendix F - Renovation of Sanitary Plumbing and Drainage Systems Using Structural Plastics Liners

## F1 General

Renovation of sanitary plumbing and drainage systems using cured-in-place (CIPP) liners (see Clause 3.16.3.1) and other structural plastic liners (see Clause 3.16.3.2) shall be performed on complete systems or as a repair of a section. The repair shall extend a minimum of 400mm beyond the damaged section of pipe in both directions with the minimum repair length to be 800mm. Where a junction is within the repair length, all arms of the junction shall be included in the repair.

### Notes:

- ✓ 1. See Figure F1.
- ✓ 2. A structural plastics liner may bridge a gap caused by damage to an existing pipeline or to line drains that may be built over.
- ✓ 3. The internal diameter of the host pipe will be reduced by twice the wall thickness of the liner. It may be necessary to consider the effect this has on the hydraulic capacity of the piping system, especially for very small diameter pipes.
- ✓ 4. There may be limitations on the use of some lining materials in trade waste applications.

# Figure F1 - Minimum Length of Liner for a Damaged Pipe or Fitting

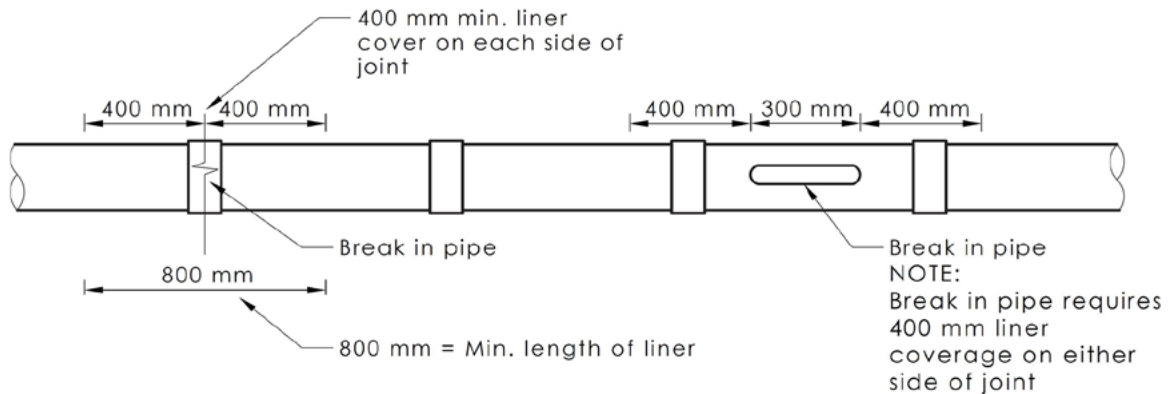

(a)

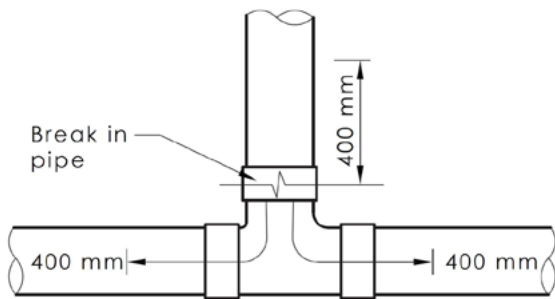

(b)

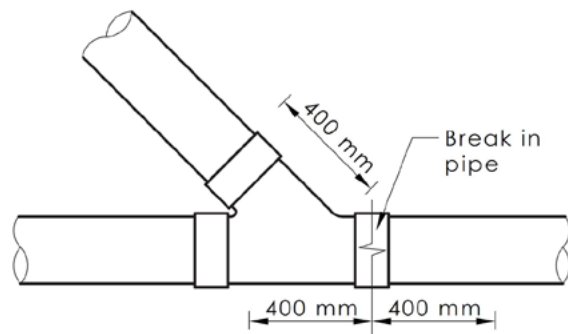

(c)

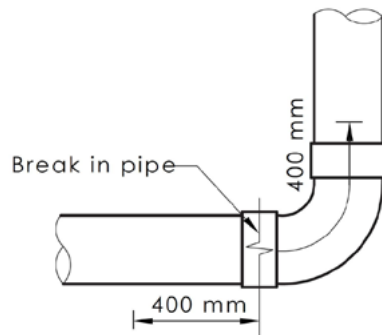

(d)

## F2 Liner

CIPP liners shall conform with WMTS-518.

When measured in accordance with ISO 7685 for thermosets (CIPP), or with ISO 9969 for thermoplastics, the minimum ring stiffness of an unsupported structural liner for below ground applications shall be 4 kN/m/m. For above ground applications the minimum pipe stiffness of the unsupported liner shall be in accordance with the appropriate product specification.

## F3 Relining Procedure

The pipe system shall be prepared for relining as follows:

- ✓ 1. A CCTV inspection shall be performed to determine whether the pipe system is in a condition suitable for renovation and to identify the location of all relevant junctions.
- ✓ 2. The pipe system shall be cleaned with a high pressure jetter.
- ✓ 3. When the renovation is to be performed using a CIPP liner, the internal surface of non-porous host pipes (e.g. PVC or PE) shall be roughened or mechanically etched using sanding discs or wire brushes.
- ✓ 4. The system shall be flushed to remove any debris.
- ✓ 5. A second CCTV inspection shall be undertaken to ensure the pipe system is ready for the liner to be installed.
- ✓ 6. The liner shall be installed.
- ✓ 7. For CIPP liners, the resin shall be cured (i.e. cross-linked) by heat, UV radiation, ambient temperature or other means.
- ✓ 8. For liners other than CIPP, the ends of the liner shall be anchored and sealed in such a way as to provide a watertight connection to the existing pipeline. The method of anchoring the pipe ends shall take account of the residual effects of installation, especially unrelieved winching and thermal stresses, and be capable of resisting the associated longitudinal forces without movement, i.e. contraction.
- ✓ 9. A third CCTV inspection shall be performed to ensure the liner has been correctly installed.
- ✓ 10. The laterals shall be reinstated by opening to the full internal diameter of the lateral. Alternatively, a one piece lateral junction liner shall be installed.
- ✓ 11. The renovated pipe system shall be flushed.
- ✓ 12. A fourth CCTV inspection shall be performed to confirm the integrity of the renovation and satisfactory condition of all laterals.

NOTE: Testing in accordance with Section 15 should be undertaken particularly in major or complete system renovations.